



TYPE-APPROVAL CERTIFICATE

Communication concerning the:

- EC type-approval,
- ~~extension of EC type approval,~~
- ~~refusal of EC type approval,~~
- ~~withdrawal of EC type approval,~~

of an ~~engine type~~/ engine family ⁽¹⁾ with regard to gaseous and particulate pollutant emission pursuant to Regulation (EU) 2016/1628, as last amended by (Commission Delegated) ⁽¹⁾ Regulation 2017/656/EU ⁽¹⁾⁽²⁾ (of the European Parliament and of the Council) ⁽¹⁾

Type Approval No: e24*2016/1628*2017/656SHA1/P*0066*00

Extension No: *N/A*

Reason for extension/refusal/withdrawal ⁽¹⁾:

- N/A

SECTION I

- | | | |
|-------|---|--|
| 1.1. | Make (trade name(s) of manufacturer): | Zomax |
| 1.2. | Commercial name(s) (if applicable): | <i>N/A</i> |
| 1.3. | Company name and address of manufacturer: | Zhejiang Zomax Garden Machinery Co.,
Ltd. No.48, Aodihu Road, Taiping
District, Wenling City,
Zhejiang, China |
| 1.4. | Name and address of manufacturer's authorised representative (if any): | Brumar Garden Products S.r.l.
Loc. Valgera 110/B - 14100 ASTI (AT) –
ITALY |
| 1.5. | Name(s) and address(es) of assembly/manufacture plant(s): | See item 1.3 above. |
| 1.6. | Engine type designation /engine family designation/FT ⁽¹⁾ : | Parent engine: ZMG1E36F
Commercial names: N/A
Engine within family: N/A
Commercial names: N/A |
| 1.7. | Category and sub-category of the engine type/engine family ⁽¹⁾⁽⁴⁾ : | Category: NRSh
Sub-category: NRSh-v-1a |
| 1.8. | Emissions durability period category: | <i>Not Applicable/Cat 1/Cat 2/Cat 3</i> ⁽¹⁾ |
| 1.9. | Emissions stage: | V/ <i>SPE</i> |
| 1.10. | Engine for snow throwers ⁽⁵⁾ : | <i>Yes/No</i> ⁽¹⁾ |

SECTION II

1. Technical service responsible for carrying out the tests: ***TÜV SÜD Auto Service GmbH,
Westendstraße 199,
D-80686 München,
Germany.***
2. Date(s) of test report(s): ***25.06.2018***
3. Number(s) of test report(s): ***18-00778-CX-SHA-00***

SECTION III

The undersigned hereby certifies the accuracy of the manufacturer's description in the attached information document of the ~~engine type~~/engine family ⁽¹⁾ described above, for which one or more representative samples, selected by the approval authority, have been submitted as prototypes and that the attached test results apply to the engine type/engine family ⁽¹⁾.

1. The ~~engine type~~/engine family ⁽¹⁾ meets/~~does not meet~~ ⁽¹⁾ the requirements laid down in Regulation (EU) 2016/1628.
 2. The approval is: ***granted/extended/refused/withdrawn*** ⁽¹⁾
 3. The approval is granted in accordance with Article 35 of Regulation (EU) 2016/1628 and the validity of the approval is thus limited to dd/mm/yyyy ⁽³⁾ ***N/A***
 4. Restrictions to validity ⁽³⁾ ⁽⁶⁾: ***N/A***
 5. Exemptions applied ⁽³⁾ ⁽⁶⁾: ***N/A***
- Place: ***Dublin.***
- Date: ***14th August, 2018***
- Name and signature
(or visual representation of an
'advanced electronic signature'
according to Regulation (EU) No 910/2014, including data for verification): 



Attachments:

Information package

Test report(s)

Where applicable, the name(s) and specimen(s) of the signature(s) of the person(s) authorised to sign statement of conformity and a statement of their position in the company Where applicable, a completed specimen of a statement of conformity

NB:

If this model is used for EU type-approval of an engine as an exemption for new technologies or new concepts, pursuant to Article 35(4) of Regulation (EU) 2016/1628, the heading of the certificate shall read 'PROVISIONAL EU TYPE-APPROVAL CERTIFICATE VALID ONLY ON THE TERRITORY OF ... ⁽⁷⁾'.

Addendum

PART A — CHARACTERISTICS OF THE ~~ENGINE TYPE~~/ENGINE FAMILY ⁽¹⁾

2. Common design parameters of the ~~engine type~~/engine family ⁽¹⁾
- 2.1. Combustion Cycle: *~~four stroke cycle/two stroke cycle/rotary~~
~~other: (describe)~~ ⁽¹⁾*
- 2.2. Ignition Type: *~~Compression ignition/spark ignition~~ ⁽¹⁾*
- 2.3.1. Position of the cylinders in the block: *~~V/in-line/radial/other(Single)~~ ⁽¹⁾*
- 2.6 Main Cooling medium: *~~Air/Water/Oil~~ ⁽¹⁾*
- 2.7. Method of air aspiration: *~~naturally aspirated/pressurecharged/
pressure charged with charge cooler~~ ⁽¹⁾*
- 2.8.1. Fuel Type(s): *~~Diesel (non-road gas-oil)/Ethanol for
dedicated compression ignition engines
(ED95)/Petrol (E10)/Ethanol(E85)/
(Natural gas/Biomethane)/Liquid
Petroleum Gas (LPG)~~ ⁽¹⁾*
- 2.8.1.1. Sub Fuel type (Natural gas/Biomethane only): *~~Universal fuel—high calorific fuel (H-
gas) and low calorific fuel(L-gas)/
Restricted fuel—high calorific fuel (H
gas)/Restricted fuel—low calorific fuel
(L-gas)/Fuel specific (LNG);~~*
- 2.8.2. Fuelling arrangement: *~~Liquid-fuel only/Gaseous-fuel only/Dual-
fuel type 1A/Dual-fuel type 1B/Dual-fuel
type 2A/Dual-fuel type 2B/Dual-fuel
type 3B~~ ⁽¹⁾*
- 2.8.3. List of additional fuels compatible with use by the engine declared by the manufacturer in accordance with point 1 of Annex I to Delegated Regulation (EU) 2017/654 (provide reference to recognised standard or specification):
- 2.8.4. Lubricant added to fuel: *~~Yes/No~~ ⁽¹⁾
~~2T FD
40:1~~*
- 2.8.5. Fuel supply type: *~~Pump (high pressure) line and injector/in
line pump or distributor pump/Unit
injector/Common rail/Carburettor/port
injector/direct injector/Mixing unit/
other(specify)~~ ⁽¹⁾*
- 2.9. Engine management systems: *~~mechanical/electronic control strategy~~ ⁽¹⁾*

- | | | |
|----------|--|----------------------------------|
| 2.10. | Miscellaneous devices: | |
| 2.10.1. | Exhaust gas recirculation (EGR): | Yes/No ⁽¹⁾ |
| 2.10.2. | Water injection: | Yes/No ⁽¹⁾ |
| 2.10.3. | Air injection: | Yes/No ⁽¹⁾ |
| 2.10.4. | Others (specify): | <i>N/A</i> |
| 2.11. | Exhaust after-treatment system: | Yes/No ⁽¹⁾ |
| 2.11.1. | Oxidation catalyst: | Yes/No ⁽¹⁾ |
| 2.11.2. | DeNOx system with selective reduction of NOx (addition of reducing agent): | Yes/No ⁽¹⁾ |
| 2.11.3. | Other DeNOx systems: | Yes/No ⁽¹⁾ |
| 2.11.4. | Three-way catalyst combining oxidation and NOx reduction: | Yes/No ⁽¹⁾ |
| 2.11.5. | Particulate after-treatment system with passive regeneration: | Yes/No ⁽¹⁾ |
| 2.11.6. | Particulate after-treatment system with active regeneration: | Yes/No ⁽¹⁾ |
| 2.11.7. | Other particulate after-treatment systems: | Yes/No ⁽¹⁾ |
| 2.11.8. | Three-way catalyst combining oxidation and NOx reduction: | Yes/No ⁽¹⁾ |
| 2.11.9. | Other after-treatment devices (specify): | <i>N/A</i> |
| 2.11.10. | Other devices or features that have a strong influence on emissions (specify): | <i>N/A</i> |

3. Essential characteristics of the engine type(s)

Item Number	Item Description	Parent Engine / Engine type	Engine types within the family (if applicable)		
3.1.1.	Engine Type Designation:	ZMG1E36F			
3.1.2.	Engine type designation shown on engine mark: Yes/No ⁽¹⁾	Yes			
3.1.3.	Location of the manufacturer's statutory marking:	Refer to drawing No. ZMG1E36F-01			
3.2.1.	Declared rated speed (rpm):	7500			
3.2.1.2.	Declared rated net Power (kW):	0.9			
3.2.2.	Maximum power speed (rpm):	7500			
3.2.2.2.	Maximum net power (kW):	0.9			
3.2.3.	Declared maximum torque speed (rpm):	6500			
3.2.3.2.	Declared maximum torque (Nm):	1.4			
3.6.3.	Number of Cylinders:	1			
3.6.4.	Engine Displacement (cm ³):	32.6			
3.8.5.	Device for recycling crankcase gases: Yes/No ⁽¹⁾	No			
3.11.3.12.	Consumable reagent: Yes/No ⁽¹⁾	No			
3.11.3.12.1.	Type and concentration of reagent needed for catalytic action:	N/A			
3.11.3.13.	NOx sensor(s): Yes/No ⁽¹⁾	N/A			
3.11.3.14.	Oxygen sensor: Yes/No ⁽¹⁾	N/A			
3.11.4.7.	Fuel borne catalyst (FBC): Yes/No ⁽¹⁾	N/A			

Particular conditions to be respected in the installation of the engine on non-road mobile machinery:

Item Number	Item Description	Parent Engine / Engine type	Engine types within the family (if applicable)		
3.8.1.1.	Maximum allowable intake depression at 100 % engine speed and at 100 % load (kPa) with clean air cleaner:	-2.0			
3.8.3.2.	Maximum charge air cooler outlet temperature at 100 % speed and 100 % load (deg. C):	<i>N/A</i>			
3.8.3.3.	Maximum allowable pressure drop across charge cooler at 100 % engine speed and at 100 % load (kPa) (if applicable):	<i>N/A</i>			
3.9.3.	Maximum permissible exhaust gas backpressure at 100 % engine speed and at 100 % load (kPa):	5.0			
3.9.3.1	Location of measurement:	Exhaust manifold			
3.11.1.2.	Maximum temperature drop from exhaust system or turbine outlet to first exhaust after-treatment system (deg. C) if stated:	<i>N/A</i>			
3.11.1.2.1.	Test conditions for measurement:	<i>N/A</i>			

PART B — TEST RESULTS

- 3.8. Manufacturer intends to use ECU torque signal for in-service monitoring: **Yes/No ⁽¹⁾**
- 3.8.1. Dynamometer torque greater than or equal to $0,93 \times$ ECU torque: **Yes/No ⁽¹⁾**
- 3.8.2. ECU torque correction factor in case that dynamometer torque less than $0,93 \times$ ECU torque: **N/A**

11.1 Cycle emissions results

Emissions	CO (g/kWh)	HC (g/kWh)	NOx (g/kWh)	HC+NOx (g/kWh)	PM (g/kWh)	PN #/kWh	Test Cycle ⁽⁸⁾
NRSC final result with DF.	173.3	-*	-*	30.1	N/A	N/A	G3
NRTC Final test result with DF	-	-	-	-	-	-	-

* (*) **Optionally, as an alternative, any combination of values satisfying the equation $(HC + NOx) \times CO^{0,784} \leq 8,57$ as well as the following conditions: $CO \leq 20,6$ g/kWh and $(HC + NOx) \leq 2,7$ g/kWh**

- 11.2 CO₂ result: **1196 g/kWh**

Explanatory notes to Annex IV:

(Footnote markers, footnotes and explanatory notes not to be stated on the EU type-approval certificate)

- (1) Strike out the unused options, or only show the used option(s).
- (2) Indicate only the latest amendment in case of an amendment of one or more Articles of Regulation (EU) 2016/1628, according to the amendment applied for the EU type-approval.
- (3) Delete this entry when not applicable.
- (4) Indicate the applicable option for the category and sub-category in accordance with entry 1.7 of the information document set out in Part A of Appendix 3 to Annex I.
- (5) Indicate whether the approval is for a NRS (< 19 kW) engine family consisting exclusively of engine types for snow throwers.
- (6) Applicable only for EU type-approval of an engine type or an engine family as an exemption for new technologies or new concepts, pursuant to Article 35 of Regulation (EU) 2016/1628.
- (7) Indicate the Member State.
- (8) Indicate the test cycle in accordance with the fifth column of the Tables set out in Annex IV to Regulation (EU) 2016/1628.



Type Approval No: e24*2016/1628*2017/656SHA1/P*0066*00

Extension No: *N/A*

Index to the Information Package

Date of issue:	<i>14th August, 2018</i>
Date of latest amendment:	<i>N/A</i>
Reason for extension/revision:	<i>N/A</i>
1. Additional conditions, and advisory notes on legal alternatives.	
2. Test report(s)	
- numbers(s):	<i>18-00778-CX-SHA-00</i>
- date of issue:	<i>25.06.2018</i>
- date of latest amendment:	<i>N/A</i>
3. Information document	
- number(s):	<i>ZMG1E36F ext.00</i>
- date of issue:	<i>12.03.2018</i>
- date of latest amendment:	<i>N/A</i>
Documentation:	<i>54 pages</i>



Type Approval No: e24*2016/1628*2017/656SHA1/P*0066*00

Extension No: *N/A*

Appendix: **Additional conditions, and advisory notes on legal alternatives**

A: Additional conditions:

1. The attached technical report, with any of its attachments, forms part of this Type Approval certificate.
2. Each type from series production shall be to the measurements specified in the attached drawings, and shall be manufactured only from the materials specified in the Approval documents.
3. Changes in the type are permitted only with the explicit permission of NSAI. Breaches of this requirement will lead to a withdrawal of the Type Approval, and in addition may be subject to criminal prosecution.
4. At regular intervals, any tests or associated checks prescribed by the applicable legislation to verify continued conformity with the approved type shall be carried out. The manufacturer shall demonstrate compliance with this by submitting to NSAI evidence of adequate arrangements and documented control plans for each type approved.
5. Any set of samples or test pieces showing evidence of non-conformity shall give rise to further sampling and testing and all steps shall be taken to restore conformity of production.
6. This Type Approval will expire when it is surrendered by the holder, or withdrawn by NSAI, or when the approved type no longer conforms to legal requirements. The recall of the Type Approval can be issued by NSAI when the conditions required for the issuing or continuation of the Type Approval are no longer current, or when the Approval holder is in breach of the duties attached to the Type Approval, or when it is established that the approved type no longer meets the requirements of traffic safety.
7. Changes in the company name, address or manufacturing site, as well as in any of the sales or other agents specified in the issuing of the approval must immediately be notified to NSAI.
8. The duties imposed by the issuing of this certificate are not transferable. The legal protection of third parties is not affected by this certificate.
9. When the manufacture or sale of the system, component or separate technical unit has not been started within one year of the date of issue of this certificate, then NSAI is to be informed. This requirement also applies when the manufacture or sale has been halted for more than one year, or when it ought to have been halted for more than one year. The initial commencement of manufacture or sale, or the resumption of manufacture or sale, shall then be notified to NSAI within one month of commencement or resumption.

B: Legal Options:

Any objection to the requirements set out in this certificate shall be made within one month of the date of issue. The objection shall be made, in writing, to NSAI in Dublin.



Techn. Report No.: 18-00778-CX-SHA-00
Manufacturer: ZHEJIANG ZOMAX GARDEN MACHINERY CO., LTD.
Type: ZMG1E36F

TECHNICAL REPORT

No.: 18-00778-CX-SHA-00

Test in accordance with the regulation of the European Parliament and the Council on requirements

relating to gaseous and particulate pollutant emission limits and type-approval for internal combustion engines for non-road mobile machinery

2016/1628/EU

of 14.09.2016

and its Commission Delegated/Implementing Regulations

2017/654/EU

of 19.12.2016

2017/655/EU

of 19.12.2016

2017/656/EU

of 19.12.2016

Approvals granted up to now		
EC	Number of approval	Date
	---	---



Techn. Report No.:	18-00778-CX-SHA-00	
Manufacturer:	ZHEJIANG ZOMAX GARDEN MACHINERY CO., LTD.	
Type:	ZMG1E36F	Page 2 of 13

1. General information

- 1.1. Make (trade name(s) of manufacturer) : ZOMAX
- 1.2. Commercial name(s) (if applicable) : N/A
- 1.3. Company name and address of manufacturer : ZHEJIANG ZOMAX GARDEN MACHINERY CO., LTD.
No.48 Aodihu Road, Taiping District, Wenling City, Zhejiang Province, China
- 1.4. Name and address of manufacturer's authorised representative (if any) : Brumar Garden Product S.r.l
Loc. Valgera 110/B-14100 ASTI (AT)-ITALY
- 1.5. Name(s) and address(es) of assembly/manufacture plant(s) : Same as above 1.3.
- 1.6. Name of technical service : TÜV SÜD Auto Service GmbH
- 1.7. Address of technical service : TÜV SÜD Certification and Testing (China) Co., Ltd. Shanghai Branch, Shanghai, P.R. China
- 1.8. Location of test : Nanjing Depurate Catalyst Co., Ltd.
- 1.9. Date of test : 24.03.2018 - 10.05.2018
- 1.10. Test report number : 18-00778-CX-SHA-00
- 1.11. Information document reference number (if available) : ZMG1E36F ext.00
- 1.12. Test report type : Primary test/additional test/supplementary test
- 1.12.1. Description of the purpose of the test : New approval test



Techn. Report No.:	18-00778-CX-SHA-00
Manufacturer:	ZHEJIANG ZOMAX GARDEN MACHINERY CO., LTD.
Type:	ZMG1E36F

2. General engine information (test engine)

- 2.1. Engine type designation/engine family designation/FT : Parent engine: ZMG1E36F
Commercial names: N/A
Engine within family: N/A
Commercial names: N/A
- 2.2. Engine identification number : ZMG1E36F180300015
- 2.3. Engine Category and subcategory : NRSh-v-1a
- 2.4. Worst Case Rationale : Test carried on parent engine

3. Documentation and information Check list (primary test only)

- 3.1. Engine mapping documentation reference : G3 cycle, test at rated speed
Declared rated speed 7500r/min
100% rated power: 0.9kW
0% rated power: 0kW
- 3.2. Deterioration factor determination documentation reference : See Annex 1
- 3.3. Infrequent regeneration factors determination documentation reference, where applicable : N/A
- 3.4. NO_x control diagnostic demonstration documentation reference, where applicable : N/A
- 3.5. Particulate control diagnostic demonstration documentation reference, where applicable : N/A
- 3.6. For engine types and engine families that use an Electronic Control Unit (ECU) as part of the emission control system anti-tampering declaration documentation reference : N/A



Techn. Report No.:	18-00778-CX-SHA-00
Manufacturer:	ZHEJIANG ZOMAX GARDEN MACHINERY CO., LTD.
Type:	ZMG1E36F

Page 4 of 13

- 3.7. For engine types and engine families that use mechanical devices as part of the emission control system anti-tampering and adjustable parameters declaration and demonstration documentation reference : Tamper-proof carburetor, the carburetor can't be adjusted by common tools, also it can't be broken with hands.
- 3.8. Manufacturer intends to use Electronic Control Unit (ECU) torque signal for in-service monitoring : ~~Yes~~/No
- 3.8.1. Dynamometer torque greater than or equal to $0.93 \times$ Electronic Control Unit (ECU) torque : ~~Yes~~/No
- 3.8.2. Electronic Control Unit (ECU) torque correction factor in case that dynamometer torque less than $0.93x$ Electronic Control Unit (ECU) torque : N/A

4. Reference fuel(s) used for test (complete relevant subparagraph(s))

4.1. *Liquid fuel for spark-ignition engines*

- 4.1.1. Make : Anhui Super Beauty Chemical Science Co., Ltd.
- 4.1.2. Type : E10
- 4.1.3. Octane number RON : 96.4
- 4.1.4. Octane number MON : 86.3
- 4.1.5. Ethanol content (%) : 9.9
- 4.1.6. Density at 15 Deg.C (kg/m³) : 746.2

4.2. *Liquid fuel for compression-ignition engines*

- 4.2.1. Make : N/A
- 4.2.2. Type : N/A
- 4.2.3. Cetane number : N/A



Techn. Report No.:	18-00778-CX-SHA-00	
Manufacturer:	ZHEJIANG ZOMAX GARDEN MACHINERY CO., LTD.	
Type:	ZMG1E36F	Page 5 of 13

- 4.2.4. Fame content (%) : N/A
- 4.2.5. Density at 15 Deg.C (kg/m³) : N/A
- 4.3. *Gaseous fuel – LPG*
- 4.3.1. Make : N/A
- 4.3.2. Type : N/A
- 4.3.3. Reference fuel type : Fuel A/Fuel B
- 4.3.4. Octane number MON : N/A
- 4.4. *Gaseous fuel- Methane/biomethane*
- 4.4.1. Reference fuel type: G_R/G₂₃/G₂₅/G₂₀ : N/A
- 4.4.2. Source of reference gas : ~~specific reference fuel/pipeline gas with admixture~~
- 4.4.3. For specific reference fuel
- 4.4.3.1 Make : N/A
- .
- 4.4.3.2 Type : N/A
- .
- 4.4.4. For pipeline gas with admixture
- 4.4.4.1 Admixture(s): : Carbon dioxide/Ethane/Methane/
Nitrogen/Propane
- .
- 4.4.4.2 The value of S_λ for the resulting fuel blend: : N/A
- .
- 4.4.4.3 The Methane Number (MN) of the resulting fuel blend : N/A
- .
- 4.5. *Dual fuel engine (in addition to relevant sections above)*
- 4.5.1. Gas energy ratio on test cycle : N/A
- 5. Lubricant**
- 5.1. Make(s) : Mobil
- 5.2. Type(s) : 2T FD

Techn. Report No.:	18-00778-CX-SHA-00	Page 6 of 13
Manufacturer:	ZHEJIANG ZOMAX GARDEN MACHINERY CO., LTD.	
Type:	ZMG1E36F	

- 5.3. SAE viscosity : 10W/40
- 5.4. Lubricant and fuel are mixed : yes/no
- 5.4.1. Percentage of oil in mixture : Oil/fuel ratio: 1/40

6. Engine Speed

- 6.1. 100% speed (rpm) : 7500
- 6.1.1. 100% speed determined by : Declared rated speed/~~Declared MTS/Measured MTS~~
- 6.1.2. Adjusted MTS if applicable (rpm) : N/A
- 6.2. Intermediate speed (rpm) : N/A
- 6.2.1. Intermediate speed determined by : ~~Declared intermediate speed/Measured intermediate speed/60% of 100% speed/75% of 100% speed /85% of 100% speed~~
- 6.3. Idle speed (rpm) : 3000

7. Engine Power

- 7.1. Engine driven equipment (if applicable)
- 7.1.1. ~~Power absorbed at indicated engine speeds by necessary auxiliaries for engine operation that cannot be fitted for the test (as specified by the manufacturer) to be shown in Table 1:~~

Table 1

Auxiliary type and identifying details	Power absorbed at indicated speed (kW) (complete relevant columns)						
	Idle	63%	80%	91%	Inter-mediate	Max. power	100%
-	-	-	-	-	-	-	-
-	-	-	-	-	-	-	-
Total (P _{f,i}) (kW):	-	-	-	-	-	-	-

- 7.1.2. ~~Power absorbed at indicated engine speeds by auxiliaries linked with operation of the machine that cannot be removed for the test (as specified by the manufacturer) to be shown in Table 2:~~

Techn. Report No.:	18-00778-CX-SHA-00	Page 7 of 13
Manufacturer:	ZHEJIANG ZOMAX GARDEN MACHINERY CO., LTD.	
Type:	ZMG1E36F	

Table 2

Auxiliary type and identifying details	Power absorbed at indicated speed (kW) (complete relevant columns)						
	Idle	63%	80%	91%	Inter-mediate	Max-power	100%
-	-	-	-	-	-	-	-
-	-	-	-	-	-	-	-
-	-	-	-	-	-	-	-
Total ($P_{r,i}$) (kW):	-	-	-	-	-	-	-

7.2. Engine net power to be stated in Table 3

Table 3

Condition	Power setting at indicated engine speed (kW) (complete relevant columns)		
	Intermediate	Max. power	100%
Maximum power measured at specified test speed ($P_{m,i}$) (kW)	N/A	N/A	0.9
Total auxiliary power from table 1 ($P_{f,i}$)	N/A	N/A	N/A
Total auxiliary power from table 2 ($P_{r,i}$)	N/A	N/A	N/A
Net engine power (kW) $P_i = P_{m,i} - P_{f,i} + P_{r,i}$	N/A	N/A	0.9

8. Conditions at test

- 8.1. f_a within range 0.93 to 1.07 : Yes/~~No~~
- 8.1.1. If f_a is not within specified range state : N/A
altitude of test facility and dry atmospheric pressure
- 8.2. Applicable intake air temperature range : : 24.6 °C
20 to 30/0 to -5(snow throwers only)/-5 to -15(snowmobiles only)/20 to 35(NRE greater than 560 kW only)

9. Information concerning the conduct of the NRSC test:

- 9.1 Cycle (mark cycle used with X)

Table 4

Cycle	C1	C2	D2	E2	E3	F	G1	G2	G3	H
Discrete mode	-	-	-	-	-	-	-	-	x	-
RMC	-	-	-	-	-	-	-	-	N/A	-

The length of each mode : 3 minutes

Sampling time for each mode : 2 minutes

9.2. Dynamometer setting (kW)

Table 5

% Load at point or % of rated power (as applicable)	Dynamometer setting (kW) at indicated engine speed after adjustment for auxiliary power (complete relevant columns)					
	Idle	63%	80%	91%	Inter- mediate	100%
0%	-	-	-	-	-	0
5%	-	-	-	-	-	-
10%	-	-	-	-	-	-
25%	-	-	-	-	-	-
50%	-	-	-	-	-	-
75%	-	-	-	-	-	-
100%	-	-	-	-	-	0.9

9.3. NRSC Emission results

9.3.1. Deterioration Factor (DF): ~~calculated~~/assigned

9.3.2. Specify the DF values and the cycle weighted emission results in the following table

Note: In the event that a discrete mode NRSC is run where the K_{ru} or K_{rd} factors have been established for individual modes then a table showing each mode and the applied K_{ru} or K_{rd} should replace the shown table

Table 6

DF mult/ add	CO	HC	NO _x	HC+NO _x	PM	PN
	1.13	-*	-*	1.03	N/A	N/A
Emissions	CO	HC	NO _x	HC+NO _x	PM	PN

	(g/kWh)	(g/kWh)	(g/kWh)	(g/kWh)	(g/kWh)	#/kWh
Test result with/without regeneration	153.12	27.22	1.94	29.16	N/A	N/A
k_{ru}/k_{rd} mult/add	N/A	N/A	N/A	N/A	N/A	N/A
test result with IRAF	N/A	N/A	N/A	N/A	N/A	N/A
Final test result with DF	173.3	-*	-*	30.1	N/A	N/A

* No DF given in the regulations.

9.3.3. Cycle weighted CO₂ (g/kWh) : 1196

9.3.4. Cycle weighted NH₃ (ppm) : N/A

9.4. Additional control area test points (if applicable)

Table 7

Emissions at test point	Engine Speed	Load (%)	CO (g/kWh)	HC (g/kWh)	NO _x (g/kWh)	HC+NO _x (g/kWh)	PM (g/kWh)	PN n/kWh
Test result 1	-	-	-	-	-	-	-	-
Test result 2	-	-	-	-	-	-	-	-
Test result 3	-	-	-	-	-	-	-	-

9.5. Sampling systems used for the NRSC test

9.5.1. Gaseous emissions : Sample system: HORIBA-CVS7100
Analyse system: MEXA-7200D
Dynamometer: KEDA3KW

9.5.2. PM : N/A

9.5.2.1 Method : ~~single/multiple filter~~

9.5.3. Particle number : N/A

10. Information concerning the conduct of the NRTC test (if applicable)

10.1. Cycle (mark cycle with X)

Table 8

NRTC	-
LSI-NRTC	-

10.2. NRTC emission results

10.2.1. Deterioration Factor (DF) \div calculated/fixed

10.2.2. DF values and the emissions results to be stated in Table 9 or in Table 10, as applicable (NRTC or LSI-NRTC):

Table 9: Table for NRTC

DF	CO	HC	NO _x	HC+NO _x	PM	PN
mult/add	-	-	-	-	-	-
Emissions	CO (g/kWh)	HC (g/kWh)	NO _x (g/kWh)	HC+NO _x (g/kWh)	PM (g/kWh)	PN #/kWh
Gold start	-	-	-	-	-	-
Hot start test result with/without regeneration	-	-	-	-	-	-
Weighted test result	-	-	-	-	-	-
k_{Fu}/k_{Fd} mult/add	-	-	-	-	-	-
Weighted test result with IRAF	-	-	-	-	-	-
Final test result with-DF	-	-	-	-	-	-

Techn. Report No.:	18-00778-CX-SHA-00	
Manufacturer:	ZHEJIANG ZOMAX GARDEN MACHINERY CO., LTD.	
Type:	ZMG1E36F	Page 11 of 13

- 10.2.3 Hot cycle CO₂ (g/kWh) ÷
- 10.2.4. Cycle weighted NH₃ (ppm) ÷
- 10.2.5. Cycle work for hot start test (kWh) ÷
- 10.2.6. Cycle CO₂ for hot start test (g) ÷

Table 10: Table for NRTC-LSI

DF	CO	HC	NO _x	HC+NO _x	PM	PN
mult/add	-	-	-	-	-	-
Emissions	CO (g/kWh)	HC (g/kWh)	NO _x (g/kWh)	HC+NO _x (g/kWh)	PM (g/kWh)	PN #/kWh
test result with/without regeneration	-	-	-	-	-	-
k_{reg}/k_{ref} mult/add	-	-	-	-	-	-
Weighted test result with IRAF	-	-	-	-	-	-
Final test result with DF	-	-	-	-	-	-

- 10.3. Cycle CO₂ (g/kWh) ÷
- 10.4. Cycle NH₃ (ppm) ÷
- 10.4.1. Cycle work (kWh) ÷
- 10.4.2. Cycle CO₂ (g) ÷
- 10.5. Sampling system used for the NRTC test ÷
- 10.6. Gaseous emissions ÷
- 10.7. PM ÷
- 10.7.1. Method ÷ single/multiple filter
- 10.8. Particle number ÷

11. Final emission result

- 11.1 Cycle emissions results

Table 11

Emissions	CO (g/kWh)	HC (g/kWh)	NO _x (g/kWh)	HC+NO _x (g/kWh)	PM (g/kWh)	PN #/kWh	Test Cycle(1)
NRSC final result with DF ⁽²⁾ .	173.3	-*	-*	30.1	N/A	N/A	G3
NRTC Final test result with DF ⁽³⁾	-	-	-	-	-	-	-

11.2 CO₂ result (g/kWh)⁽⁴⁾ : 1196

Emission limits

	CO	HC	NO _x	HC+NO _x	PM	PN
NRSh-v-1a	805	-	-	50	-	-
NRSh-v-1b	603	-	-	72	-	-
NRS-vr-1a	610	-	-	10	-	-
NRS-vr-1b	610	-	-	8	-	-
NRS-vi-1a	610	-	-	10	-	-
NRS-vi-1b	610	-	-	8	-	-
NRS-v-2a	610	-	-	8	-	-
NRS-v-2b	4,40(*)	-	-	2,70(*)	-	-
NRS-v-3	4,40(*)	-	-	2,70(*)	-	-

(*) Optionally, as an alternative, any combination of values satisfying the equation $(HC + NO_x) \times CO^{0.784} \leq 8,57$ as well as the following conditions: $CO \leq 20,6$ g/kWh and $(HC + NO_x) \leq 2,7$ g/kWh

- (1) For NRSC note the cycle indicated in point 9.1.; for NRTC note cycle indicated in point 10.1.
- (2) Copy the results from table 9.3.2.
- (3) Copy the results from table 10.2.2. or 10.3.6., as applicable
- (4) For an engine type or engine family tested on the NRTC and NRSC indicate the emission values given in the CO₂ section 10.3.3. (NRTC). For an engine only tested in an NRSC indicate the emission values given in the CO₂ column section 9.3.3.

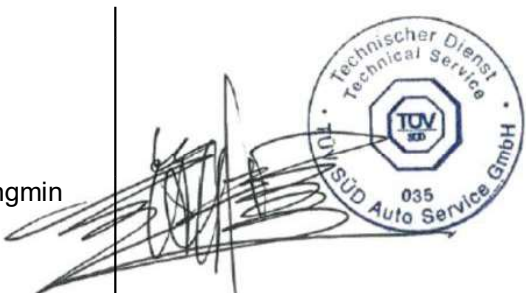

Techn. Report No.:	18-00778-CX-SHA-00	Page 13 of 13
Manufacturer:	ZHEJIANG ZOMAX GARDEN MACHINERY CO., LTD.	
Type:	ZMG1E36F	

CONCLUSION	<p>The information folder as mentioned above and the type described therein are in compliance with the test specification mentioned above. The worst-case was selected in accordance with document "Preparation of Test Reports".</p> <p>The test report may be reproduced and published in full and by the client only. It can be reproduced partially with the written permission of the test laboratory only.</p> <p style="text-align: center;">Signature: _____</p> <p style="text-align: center;">Name: Zhao, Chongmin Position: Expert Date: 25.06.2018</p> <div style="text-align: right;">  </div>
-------------------	--

Genehmigungsbehörde/ Approval authority	Land/Country	Registriernummer/ Registration-number	Aktueller Benennungsumfang/ Actual scope list
Kraftfahrt-Bundesamt (KBA)	Deutschland/ Germany	KBA-P 00100-10	www.kba.de
Vehicle Certification Agency (VCA)	Vereintes Königreich/ United Kingdom	VCA-TS-006	http://ec.europa.eu/enterprise/sectors/automotive/approval-authorities-technical-services/technical-services/index_en.htm
Approval Authority of the Netherlands (RDW)	Niederlande/ The Netherlands	RDWT-082-XX	
National Standards Authority of Ireland (NSAI)	Irland/ Ireland	Technical Service Number: 49	
Vehicle Safety Certification Center (VSCC)	Taiwan/ Taiwan	DE04-06-2	http://www.vsc.org.tw/English/Default.aspx



Techn. Report No.:	18-00778-CX-SHA-00	Annex 1
Manufacturer:	ZHEJIANG ZOMAX GARDEN MACHINERY CO., LTD.	
Type:	ZMG1E36F	Page 1 of 2

Determination of deterioration factor

ZMG1E36F parent engine (engine No: ZMG1E36F180300015)

	New stabilized engine	engine after 50 aging cycle	DF
CO	153.12 g/kWh	173.26 g/kWh	1.13
HC	27.22 g/kWh	29.76 g/kWh	-*
NO _x	1.94 g/kWh	0.29 g/kWh	-*
HC + NO _x	29.16 g/kWh	30.05 g/kWh	1.03

* No DF given in the regulations.

Aging cycle (started at 27.04.2018)

发动机型号	ZMG1E36F		发动机编号	ZMG1E36F180300015			制造单位	浙江中马园林机器股份有限公司			试验台架	I		试验	周志荣 王志林					
燃油	95#		润滑油	2T FD			混合比	40:1			燃油密度	0.735		审核	付业龙					
试验日期	时间	累计耐久运行时间	转速	扭矩	功率	耗油量	耗油时间	燃油耗率	火花塞 垫圈温度	大气 压力	进气 温度	相对 湿度	备注							
yyyy-mm-dd	hh:mm	hh:mm	r/min	Nm	kW	ml	s	g/kWh	°C	kPa	°C	%								
2018/4/27	9:00	0:00	7504	1.19	0.94	20	125.00	452.8	265	100.6	24.0	68.0	磨合10小时后排放初测后开始耐久试验。							
	10:00	1:00	7504	1.18	0.93	20	125.00	456.6	265	100.6	24.5	68.0								
	11:00	2:00	7505	1.17	0.92	20	123.00	467.9	265	100.6	24.5	68.0								
	12:00	3:00	7505	1.16	0.91	20	123.00	472.0	265	100.6	24.5	68.0								
	13:00	4:00	7507	1.16	0.91	20	125.00	464.3	265	100.6	24.5	68.0								
	14:00	5:00	7507	1.17	0.92	20	125.00	460.3	265	100.6	24.5	68.0								
	15:00	6:00	7510	1.19	0.94	20	126.00	448.8	268	100.6	24.5	68.0								
	16:00	7:00	7507	1.17	0.92	20	126.00	456.7	268	100.6	24.5	67.0								
	17:00	8:00	7505	1.15	0.90	20	127.00	461.1	268	100.6	24.5	67.0								
	18:00	9:00	7503	1.17	0.92	20	127.00	453.3	268	100.6	24.5	67.0								
	19:00	10:00	7501	1.20	0.94	20	123.00	456.5	268	100.6	25.0	67.0					发动机运行正常,停机5min.检查发动机的连接紧固件。			
	20:00	11:00	7504	1.13	0.89	20	123.00	484.6	268	100.6	25.0	67.0								
	21:00	12:00	7507	1.17	0.92	20	123.00	467.8	268	100.6	25.0	67.0								
22:00	13:00	7503	1.12	0.88	20	123.00	489.0	270	100.6	25.0	65.0									
23:00	14:00	7507	1.16	0.91	20	124.00	468.0	270	100.6	25.0	66.0									
2018/4/28	0:00	15:00	7511	1.50	1.18	20	123.00	364.7	270	100.6	25.0	66.0								
	1:00	16:00	7512	1.15	0.90	20	121.00	483.5	270	100.6	25.0	66.0								
	2:00	17:00	7510	1.15	0.90	20	123.00	475.8	270	100.6	25.0	66.0								
	3:00	18:00	7513	1.16	0.91	20	123.00	471.5	269	100.6	25.0	66.0								
	4:00	19:00	7522	1.16	0.91	20	125.00	463.4	269	100.6	25.0	66.0								
	5:00	20:00	7520	1.17	0.92	20	118.00	466.8	269	100.6	25.0	66.0								
	6:00	21:00	7515	1.18	0.93	20	118.00	483.0	270	100.6	25.0	65.0	发动机运行正常,停机15min.清洗火花塞、清理空滤器、检查连接紧固件。							
	7:00	22:00	7519	1.12	0.88	20	120.00	500.1	270	100.6	25.0	65.0								
8:00	23:00	7517	1.11	0.87	20	120.00	504.7	270	100.6	25.0	65.0									
9:00	24:00	7512	1.13	0.89	20	120.00	496.1	270	100.6	25.0	65.0									



Techn. Report No.: 18-00778-CX-SHA-00 Annex 1
 Manufacturer: ZHEJIANG ZOMAX GARDEN MACHINERY CO., LTD.
 Type: ZMG1E36F Page 2 of 2

发动机型号	ZMG1E36F		发动机编号	ZMG1E36F180300015			制造单位	浙江中马园林机器股份有限公司		试验台架	1		试验	周志荣 王志林	
燃油	95#		润滑油	2T FD			混合比	40:1		燃油密度	0.735		审核	付业龙	
试验日期	时间	累计耐久运行时间	转速	扭矩	功率	耗油量	耗油时间	燃油耗率	火花塞 垫圈温度	大气 压力	进气 温度	相对 湿度	备注		
yyyy-mm-dd	hh:mm	hh:mm	r/min	Nm	kW	ml	s	g/kWh	°C	kPa	°C	%			
	10:00	25:00	7512	1.16	0.91	20	119.00	487.3	270	101.7	24.0	68.0	磨合10小时累计运行25小时测得结果,耐久试验进程一半,发动机正常,等待做排放试验。		
2018/4/29	9:00	26:00	7510	1.16	0.91	20	119.00	487.5	270	100.6	24.0	68.0			
	10:00	27:00	7510	1.13	0.89	20	119.00	500.4	270	100.6	24.0	68.0			
	11:00	28:00	7511	1.14	0.90	20	119.00	496.0	269	100.6	24.0	68.0			
	12:00	29:00	7513	1.16	0.91	20	121.00	479.2	269	100.6	24.0	68.0			
	13:00	30:00	7512	1.15	0.90	20	121.00	483.5	269	100.6	24.0	68.0	发动机运行正常,停机5min,检查发动机的连接紧固件。		
	14:00	31:00	7507	1.15	0.90	20	121.00	483.8	270	100.6	24.0	68.0			
	15:00	32:00	7507	1.15	0.90	20	121.00	483.8	270	100.6	24.0	68.0			
	16:00	33:00	7506	1.15	0.90	20	120.00	487.9	270	100.6	24.0	68.0			
	17:00	34:00	7512	1.15	0.90	20	121.00	483.5	270	100.6	24.0	68.0			
	18:00	35:00	7513	1.13	0.89	20	120.00	496.0	270	100.6	24.0	68.0			
	19:00	36:00	7517	1.13	0.89	20	119.00	499.9	270	100.6	24.0	68.0			
	20:00	37:00	7513	1.13	0.89	20	118.00	504.4	270	100.6	24.0	68.0			
	21:00	38:00	7512	1.11	0.87	20	119.00	509.3	271	100.6	24.0	68.0			
	22:00	39:00	7512	1.11	0.87	20	122.00	496.8	271	100.6	24.0	68.0			
	23:00	40:00	7511	1.12	0.88	20	122.00	492.4	271	100.6	24.0	68.0	发动机运行正常,停机5min,检查发动机的连接紧固件。		
2018/4/30	0:00	41:00	7507	1.12	0.88	20	122.00	492.7	270	100.6	24.0	68.0			
	1:00	42:00	7507	1.12	0.88	20	125.00	480.8	270	100.6	24.0	68.0			
	2:00	43:00	7506	1.13	0.89	20	125.00	476.7	270	100.6	24.0	68.0			
	3:00	44:00	7504	1.13	0.89	20	125.00	476.8	268	100.6	24.0	68.0			
	4:00	45:00	7501	1.13	0.89	20	123.00	484.7	268	100.6	24.0	68.0			
	5:00	46:00	7501	1.16	0.91	20	123.00	472.2	268	100.6	24.0	68.0			
	6:00	47:00	7501	1.16	0.91	20	120.00	484.0	268	100.6	24.0	68.0			
	7:00	48:00	7502	1.16	0.91	20	120.00	483.9	268	100.6	24.0	68.0			
	8:00	49:00	7503	1.15	0.90	20	121.00	484.0	270	100.6	24.0	68.0			
	9:00	50:00	7507	1.15	0.90	20	123.00	475.9	269	100.6	24.0	68.0	磨合10小时累计运行50小时测得结果,耐久试验进程完成,发动机正常,等待做排放试验。		

PARTIAL MODEL INFORMATION DOCUMENT

No.:ZMG1E36F ext.00

ZOMAX

ZHEJIANG ZOMAX GARDEN MACHINERY CO., LTD.

ENGINE TYPE : ZMG1E36F

SUBJECT : NRMM EMISSION

LEGAL BASIS : 2016/1628/EU

Date : 2018-3-12 [YYYY-MM-DD]

Approval : Zhang Ping

Position : Homologation Engineer

AMENDMENT

Version	Approval No.	Modification / Correction	Date
-	-	-	-
-	-	-	-
-	-	-	-
-	-	-	-
-	-	-	-

CONTENT

1.	General information.....	3
2.	Common design parameters of engine family	4
3.	Essential characteristics of the engine type(s).....	6
Attachment 1	Photographs of the engines	23
Attachment 2	Drawings of the engines	24
Attachment 3	Manufacturer’s declaration on compliance with Regulation (EU) 2016/1628	34
Attachment 4	Manufacturer’s statement on compliance with the exhaust emission limits when use fuels other than the reference fuels.....	35
Attachment 5	Overview of the emission control strategy for electronically controlled engines.....	35
Attachment 6	The functional operational characteristics of the NOx control measures and inducement system	35
Attachment 7	The functional operational characteristics of the particulate control measures	35
Attachment 8	Manufacturer’s declaration, and supporting test reports or data, on deterioration factors	36
Attachment 9	Manufacturer’s declaration, and supporting test reports or data, of the infrequent regeneration adjustment factors.....	37
Attachment 10	The physical connector required to receive the torque signal from the engine Electronic control Unit (ECU) during the in-service monitoring test.....	37
Attachment 11	Manufacturer’s declaration and supporting data on tampering prevention for emission control systems.....	38
Attachment 12	List of scheduled for emission-related maintenance requirements.....	<u>39</u>

Part A

1. General information

- | | | | |
|---------|--|---|--|
| 1.1. | Make (trade name(s) of manufacturer) | : | ZOMAX |
| 1.2. | Commercial name(s) (if applicable) | : | N/A |
| 1.3. | Company name and address of manufacturer | : | ZHEJIANG ZOMAX GARDEN MACHINERY
CO., LTD.
No.48 Aodihu Road, Taiping District, Wenling
City, Zhejiang Province, China |
| 1.4. | Name and address of manufacturer's
authorised representative (if any) | : | Brumar Garden Product S.r.l
Loc. Valgera 110/B-14100 ASTI (AT)-ITALY |
| 1.5. | Name(s) and address(es) of
assembly/manufacture plant(s) | : | ZHEJIANG ZOMAX GARDEN MACHINERY
CO., LTD.
No.48 Aodihu Road, Taiping District, Wenling
City, Zhejiang Province, China |
| 1.6. | Engine type designation/engine family
designation/FT | : | Parent engine: ZMG1E36F
Commercial names: N/A
Engine within family: N/A
Commercial names: N/A |
| 1.7. | Category and sub-category of the engine
type/engine family | : | Category: NRSh
Sub-category: NRSh-v-1a |
| 1.8. | Emissions durability period category | : | Not Applicable/
Cat 1 (Consumer products)/
Cat 2 (Semi-professional products)/
Cat 3 (Professional products) |
| 1.9. | Emissions stage | : | V/Special Purpose Engine (SPE) |
| 1.10. | In case of NRS <19 kW only, engine family
consisting exclusively of engine types for snow
throwers | : | Yes/No |
| 1.11. | Reference power is | : | rated net power/ maximum net power |
| 1.12. | Primary NRSC test cycle | : | C1/C2/D2/E2/E3/F/G1/G2/G3/H |
| 1.12.1. | In case of variable speed IWP category only,
Additional propulsion test cycle | : | Not applicable/E2/E3 |
| 1.12.2. | In case of IWP category only, additional
auxiliary NRSC test cycle | : | Not applicable/D2/G1 |
| 1.13. | Transient test cycle | : | Not applicable/NRTC/LSI-NRTC |
| 1.14. | Restrictions on use (if applicable) | : | N/A |

Part B

2. Common design parameters of engine family

- 2.1. Combustion Cycle : ~~four stroke cycle~~/two stroke cycle/~~rotary~~/~~other (specify)~~
- 2.2. Ignition Type : ~~Compression ignition~~/spark ignition
- 2.3. Configuration of the cylinders**
- 2.3.1. Position of the cylinders in the block : ~~Single V~~/~~in-line~~/~~opposed~~/~~radial~~/~~other(specify)~~
- 2.3.2. Bore centre to centre dimension (mm) : N/A
- 2.4. Combustion chamber type/design**
- 2.4.1. Open chamber/divided chamber/other(specify) : Open chamber
- 2.4.2. Valve and porting configuration : Refer to drawing No. ZMG1E36F-02
- 2.4.3. Number of valves per cylinder : N/A
- 2.5. Range of individual cylinder displacement (cm³) : See item 3.6.4. in Part C
- 2.6. Main Cooling medium : ~~Air~~/~~Water~~/~~Oil~~
- 2.7. Method of air aspiration : ~~naturally aspirated~~/~~pressure charged~~/~~pressure charged with charge cooler~~
- 2.8. Fuel**
- 2.8.1. Fuel Type : ~~Diesel (non-road gas-oil)~~/~~Ethanol for dedicated compression ignition engines (ED95)~~/~~Petrol (E10)~~/~~Ethanol (E85)~~/~~Natural gas~~/~~Biomethane~~/~~Liquid Petroleum Gas (LPG)~~
- 2.8.1.1. Sub Fuel type (Natural gas/Biomethane only) : ~~Universal fuel—high calorific fuel (H gas) and low calorific fuel (L gas)~~/~~Restricted fuel—high calorific fuel (H gas)~~/~~Restricted fuel—low calorific fuel (L gas)~~/~~Fuel specific (LNG)~~
- 2.8.2. Fuelling arrangement : ~~Liquid-fuel only~~/~~Gaseous fuel only~~/~~Dual fuel type 1A~~/~~Dual fuel type 1B~~/~~Dual fuel type 2A~~/~~Dual fuel type 2B~~/~~Dual fuel type 3B~~
- 2.8.3. List of additional fuels, fuel mixtures or emulsions compatible with use by the engine declared by the manufacturer in accordance with point 1.4 of Annex I to Delegated Regulation (EU) 2017/654 (provide reference to recognised standard or specification) : N/A
- 2.8.4. Lubricant added to fuel : Yes/~~No~~
- 2.8.4.1. Specification : N/A
- 2.8.4.2. Ratio of fuel to oil : 40:1 (2T FD)
- 2.8.5. Fuel supply type : ~~Pump (high pressure) line and injector~~/~~in-line pump or distributor pump~~/~~Unit injector~~/~~Common rail~~/~~Carburettor~~/~~port injector~~/~~direct injector~~/~~Mixing unit~~/~~other(specify)~~
:
- 2.9. Engine management systems : ~~mechanical~~/~~electronic control strategy~~⁽²⁾

2.10. Miscellaneous devices

- 2.10.1. Exhaust gas recirculation: Yes/No : No
(if yes, complete section 3.10.1. and provide a schematic diagram of the location and order of the devices)
- 2.10.2. Water injection: Yes/No : No
(if yes, complete section 3.10.2. and provide a schematic diagram of the location and order of the devices)
- 2.10.3. Air injection: Yes/No : No
(if yes, complete section 3.10.3. and provide a schematic diagram of the location and order of the devices)
- 2.10.4. Others (specify and provide a schematic diagram of the location and order of the devices) : N/A
- 2.11. Exhaust after-treatment system : Yes/No**
(if yes provide a schematic diagram of the location and order of the devices)
- 2.11.1. Oxidation catalyst : ~~Yes/No~~
(if yes, complete section 3.11.2.)
- 2.11.2. DeNOx system with selective reduction of NOx : ~~Yes/No~~
(addition of reducing agent)
(if yes, complete section 3.11.3.)
- 2.11.3. Other DeNOx systems : ~~Yes/No~~
(if yes, complete section 3.11.3.)
- 2.11.4. Three-way catalyst combining oxidation and NOx reduction : ~~Yes/No~~
(if yes, complete section 3.11.3.)
- 2.11.5. Particulate trap with passive regeneration : ~~Yes/No~~
(if yes, complete section 3.11.4.)
- 2.11.6. Particulate trap with active regeneration : ~~Yes/No~~
(if yes, complete section 3.11.4.)
- 2.11.7. Other particulate traps : ~~Yes/No~~
(if yes, complete section 3.11.4.)
- 2.11.8. Other after-treatment devices (specify) : ~~Yes/No~~
(if yes, complete section 3.11.5.)
- 2.11.9. Other devices or features that have a strong influence on emissions (specify) : N/A

Part C

3. Essential characteristics of the engine type(s)

Item Number	Item Description	Test	Installation	Homologation	Parent engine/ engine type	Engine types within the engine family (if applicable)		
3.1	Engine Identification							
3.1.1.	Engine type designation			X	ZMG1E36F			
3.1.2.	Engine type designation shown on engine marking:			X	Yes			
3.1.3.	Location of the statutory marking: yes/no			X	Refer to drawing No. ZMG1E36F-01			
3.1.4.	Method of attachment of the statutory marking:			X	Paste			
3.1.5.	Drawings of the location of the engine identification number (complete example with dimensions):			X	Refer to drawing No. ZMG1E36F-01			
3.2.	Performance Parameters							
3.2.1.	Declared rated speed (rpm):	X			7500			
3.2.1.1.	Fuel delivery/stroke (mm ³) for diesel engine, fuel flow (g/h) for other engines, at rated net power:			X	440			
3.2.1.2.	Declared rated net power (kW):	X			0.9			
3.2.2.	Maximum power speed(rpm):			X	7500			
3.2.2.1.	Fuel delivery/stroke (mm ³) for diesel engine, fuel flow (g/h) for other engines, at maximum net power:			X	440			
3.2.2.2.	Maximum net power (kW):	X		X	0.9			
3.2.3.	Declared maximum torque speed (rpm):	X			6500			

Item Number	Item Description	Test	Installation	Homologation	Parent engine/ engine type	Engine types within the engine family (if applicable)		
3.2.3.1.	Fuel delivery/stroke (mm ³) for diesel engine, fuel flow (g/h) for other engines, at maximum torque speed:			X	473			
3.2.3.2.	Declared maximum torque (Nm):	X			1.4			
3.2.4.	Declared 100% test speed:	X			7500			
3.2.5.	Declared Intermediate test speed:	X			N/A			
3.2.6.	Idle speed (rpm)	X			3000			
3.2.7.	Maximum no load speed (rpm):	X			10000			
3.2.8.	Declared minimum torque (Nm)	X			N/A			
3.3.	Run-in procedure							
3.3.1.	Run in time:	X			N/A			
3.3.2.	Run-in cycle:	X			N/A			
3.4.	Engine test							
3.4.1.	Specific fixture required: Yes/No	X			Yes/No			
3.4.1.1.	Description, including photographs and/or drawings, of the system for mounting the engine on the test bench including the power transmission shaft for connection to the dynamometer:	X			N/A			
3.4.2.	Exhaust mixing chamber permitted by manufacturer: Yes/No	X			No			
3.4.2.1.	exhaust mixing chamber description, photograph and/or drawing:	X			N/A			
3.4.3.	Manufacturers chosen NRSC: RMC/Discrete mode	X			Discrete mode			
3.4.4.	Additional NRSC: E2/D2/C1	X			N/A			

Item Number	Item Description	Test	Installation	Homologation	Parent engine/ engine type	Engine types within the engine family (if applicable)		
3.4.5.	Number of pre-conditioning cycles prior to transient test	X			N/A			
3.4.6.	Number of pre-conditioning RMC prior to RMC NRSC test	X			N/A			
3.5.	Lubrication system							
3.5.1.	<i>Lubricant temperature</i>							
3.5.1.1.	Minimum (deg. C):	X			N/A			
3.5.1.2.	Maximum (deg. C):	X			N/A			
3.6.	Combustion Cylinder							
3.6.1.	Bore(mm):			X	36			
3.6.2.	Stroke(mm):			X	32			
3.6.3.	Number of cylinders:			X	1			
3.6.4.	Engine displacement (cm ³):			X	32.6			
3.6.5.	Cylinder displacement as % of parent engine:			X	100%			
3.6.6.	Volumetric compression ratio:			X	9.2 :1			
3.6.7.	Combustion system description:			X	N/A			
3.6.8.	Drawings of combustion chamber and piston crown:			X	Refer to drawing no. ZMG1E36F-02 & ZMG1E36F-03			
3.6.9.	Minimum cross sectional area of inlet and outlet ports (mm ²):			X	Inlet 106.2 mm ² , Outlet 94.9 mm ²			
3.6.10.	<i>Valve timing</i>							

Item Number	Item Description	Test	Installation	Homologation	Parent engine/ engine type	Engine types within the engine family (if applicable)		
3.6.10.1.	Maximum lift and angles of opening and closing in relation to dead centre or equivalent data:			X	Refer to drawing No. ZMG1E36F-05			
3.6.10.2.	Reference and/or setting range:			X	N/A			
3.6.10.3.	Variable valve timing system: Yes/No			X	No			
3.6.10.3.1.	Type: continuous/(on/off)			X	N/A			
3.6.10.3.2.	Cam phase shift angle:			X	N/A			
3.6.11.	<i>Porting configuration</i>							
3.6.11.1.	positon, size and number:			X	Refer to drawing No. ZMG1E36F-02			
3.7.	Cooling system							
3.7.1.	<i>Liquid cooling</i>							
3.7.1.1.	Nature of liquid:			X	N/A			
3.7.1.2.	Circulating pumps: Yes/No			X	No			
3.7.1.2.1.	type(s):			X	N/A			
3.7.1.2.2.	Drive ratio(s):			X	N/A			
3.7.1.3.	Minimum coolant temperature at outlet (deg. C):	X			N/A			
3.7.1.4.	Maximum coolant temperature at outlet (deg. C):	X			N/A			
3.7.2.	<i>Air cooling</i>							
3.7.2.1.	fan: Yes/No			X	N/A			
3.7.2.1.0.	Make:			X	N/A			
3.7.2.1.1.	type(s):			X	N/A			

Item Number	Item Description	Test	Installation	Homologation	Parent engine/ engine type	Engine types within the engine family (if applicable)		
3.7.2.1.2.	Drive ratio(s):			X	N/A			
3.7.2.2.	Maximum temperature at reference point (deg. C):			X	N/A			
3.7.2.2.1.	Reference point location			X	N/A			
3.8.	Aspiration							
3.8.1.	Maximum allowable intake depression at 100% engine speed and at 100% load (kPa)	X	X					
3.8.1.1.	With clean air cleaner:	X	X		-2.0			
3.8.1.2.	With dirty air cleaner:	X	X		-2.0			
3.8.1.3.	Location, of measurement:	X	X		Intake manifold			
3.8.2.	Pressure charger(s): Yes/No			X	No			
3.8.2.0.	Make:			X	N/A			
3.8.2.1.	Type(s):			X	N/A			
3.8.2.2.	Description and schematic diagram of the system (e.g. maximum charge pressure,-waste gate, VGT, Twin turbo, etc.):			X	N/A			
3.8.3.	Charge air cooler: Yes/No			X	No			
3.8.3.1.	Type: air-air/air-water/other(specify)			X	N/A			
3.8.3.2.	Maximum charge air cooler outlet temperature at 100% speed and 100% load (deg. C):	X	X		N/A			
3.8.3.4.	Maximum allowable pressure drop across charge cooler at 100% engine speed and at 100% load (kPa):	X	X		N/A			
3.8.4.	Intake throttle valve: Yes/No			X	Yes			
3.8.5.	Device for recycling crankcase gases: Yes/No			X	No			

Item Number	Item Description	Test	Installation	Homologation	Parent engine/ engine type	Engine types within the engine family (if applicable)		
3.8.5.1.	If yes, description and drawings:			X	N/A			
3.8.5.2.	If no, compliance with paragraph 6.10 of Annex VI to Delegated Regulation (EU) 2017/654: Yes/No	X			N/A			
3.8.6.	<i>Inlet path</i>							
3.8.6.1.	Description of inlet path, (with drawings, photographs and/or part numbers):			X	Refer to drawing No. ZMG1E36F-08			
3.8.7.	Air filter			X	Yes			
3.8.7.0.	Make:			X	N/A			
3.8.7.1.	Type:			X	4.005.0053.04 (4.005.0053.07)			
3.8.8.	Intake air-silencer							
3.8.1.0.	Make:			X	N/A			
3.8.1.1.	Type:			X	N/A			
3.9.	Exhaust system							
3.9.1.	Description of the exhaust system (with drawings, photos and/or part numbers as required):			X	Refer to drawing No. ZMG1E36F-07			
3.9.2.	Maximum exhaust temperature (deg. C):	X			650			
3.9.3.	Maximum permissible exhaust backpressure at 100% engine speed and at 100% load (kPa):	X	X		5.0			
3.9.3.1.	Location of measurement:	X	X		Exhaust manifold			

Item Number	Item Description	Test	Installation	Homologation	Parent engine/ engine type	Engine types within the engine family (if applicable)		
3.9.4.	Exhaust backpressure at loading level specified by manufacturer for variable restriction after-treatment at start of test (kPa):	X			N/A			
3.9.4.1.	Location and speed/load conditions:	X			N/A			
3.9.5.	Exhaust throttle valve: Yes/No			X	No			
3.10.	Miscellaneous devices: Yes/No				No			
3.10.1.	<i>Exhaust gas recirculation (EGR)</i>				N/A			
3.10.1.1.	Characteristics: cooled/uncooled, high pressure/low pressure/other (specify):				N/A			
3.10.2.	<i>Water injection</i>				N/A			
3.10.2.1.	Operation principle:			X	N/A			
3.11.	Exhaust after-treatment system							
3.11.1.	<i>Location</i>		X		In the center of muffler			
3.11.1.1.	Place(s) and maximum/minimum distance(s) from engine to first after-treatment device:		X		N/A			
3.11.1.2.	Maximum temperature drop from exhaust or turbine outlet to first after-treatment device (deg. C) if stated:	X	X		N/A			
3.11.1.2.1.	Test conditions for measurement:	X	X		N/A			
3.11.1.3.	Minimum temperature at inlet to first after-treatment device at 100% load and speed (deg. C), if stated:	X	X		N/A			
3.11.2.	Oxidation catalyst							
3.11.2.0.	Make/type:			X	Depurate/ 4.006.0071.03			

Item Number	Item Description	Test	Installation	Homologation	Parent engine/ engine type	Engine types within the engine family (if applicable)		
3.11.2.1.	Number of catalytic converters and elements:			X	1			
3.11.2.2.	Dimensions and volume of the catalytic converter(s):			X	Refer to drawing No. ZMG1E36F- 10			
3.11.2.3.	Total charge of precious metals:			X	N/A			
3.11.2.4.	Relative concentration of each compound:			X	Pt:Pd:Rh=0:5:1			
3.11.2.5.	Substrate (structure and material):			X	metal			
3.11.2.6.	Cell density:			X	70g/ft ³			
3.11.2.7.	Type of casing for the catalytic converter(s):			X	Steel casing			
3.11.3.	<i>Catalytic exhaust gas after treatment system for NO_x or three way catalyst</i>				N/A			
3.11.3.0.	Make:			X	N/A			
3.11.3.1.	Type:			X	N/A			
3.11.3.2.	Number of catalytic converters and elements:			X	N/A			
3.11.3.3.	Type of catalytic action:			X	N/A			
3.11.3.4.	Dimensions and volume of the catalytic converter(s):			X	N/A			
3.11.3.5.	Total charge of precious metals:			X	N/A			
3.11.3.6.	Relative concentration of each compound:			X	N/A			
3.11.3.7.	Substrate (structure and material):			X	N/A			
3.11.3.8.	Cell density:			X	N/A			
3.11.3.9.	Type of casing for the catalytic converter(s):			X	N/A			
3.11.3.10.	Method of regeneration:	X		X	N/A			
3.11.3.10.1.	Infrequent regeneration: Yes/No:	X			No			

Item Number	Item Description	Test	Installation	Homologation	Parent engine/ engine type	Engine types within the engine family (if applicable)		
3.11.3.11.	Normal operating temperature range (deg. C):	X	X		N/A			
3.11.3.12.	Consumable reagent: Yes/No			X	No			
3.11.3.12.1.	Type and concentration of reagent needed for catalytic action:			X	N/A			
3.11.3.12.2.	Lowest concentration of the active ingredient present in the reagent that does not activate warning system (CD _{min}) (%vol):			X	N/A			
3.11.3.12.3.	Normal operational temperature range of reagent:		X		N/A			
3.11.3.12.4.	International standard:		X	X	N/A			
3.11.3.13.	NO _x sensor(s): Yes/No			X	No			
3.11.3.13.0.	Make:			X	N/A			
3.11.3.13.1.	Type:			X	N/A			
3.11.3.13.2.	Location(s)			X	N/A			
3.11.3.14.	Oxygen sensor(s): Yes/No			X	No			
3.11.3.14.0.	Make:			X	N/A			
3.11.3.14.1.	Type:			X	N/A			
3.11.3.14.2.	Location(s):			X	N/A			
3.11.4.	<i>Particulate after-treatment system</i>				N/A			
3.11.4.1.	Type of filtration: wall-flow/ non-wall-flow/other (specify)			X	N/A			
3.11.4.2.	Make:			X	N/A			
3.11.4.2.	Type:			X	N/A			

Item Number	Item Description	Test	Installation	Homologation	Parent engine/ engine type	Engine types within the engine family (if applicable)		
3.11.4.3.	Dimensions and capacity of the particulate after-treatment system:			X	N/A			
3.11.4.4.	Location place(s) and maximum and minimum distance(s) from engine:		X		N/A			
3.11.4.5.	Method or system of regeneration, description and/or drawing:			X	N/A			
3.11.4.5.1.	Infrequent regeneration: Yes/No			X	No			
3.11.4.5.2.	Minimum exhaust gas temperature for initiating regeneration procedure (deg. C):			X	N/A			
3.11.4.6.	Catalytic coating: Yes/No			X	No			
3.11.4.6.1.	Type of catalytic action:			X	N/A			
3.11.4.7.	Fuel borne catalyst (FBC): Yes/No			X	No			
3.11.4.8.	Normal operating temperature range (deg. C):			X	N/A			
3.11.4.9.	Normal operating pressure range (kPa)			X	N/A			
3.11.4.10.	Storage capacity soot/ash [g]:			X	N/A			
3.11.4.11	Oxygen sensor(s): Yes/No			X	No			
3.11.4.11.1	Type:			X	N/A			
3.11.4.11.2	Location(s):			X	N/A			
3.11.5.	<i>Other systems</i>				N/A			
3.11.5.1.	Description and operation:			X	N/A			
3.11.6.	Infrequent Regeneration				N/A			
3.11.6.1.	Number of cycles with regeneration	X			N/A			
3.11.6.2.	Number of cycles without regeneration	X			N/A			

Item Number	Item Description	Test	Installation	Homologation	Parent engine/ engine type	Engine types within the engine family (if applicable)		
3.12.	Fuel feed for liquid-fuelled CI or, where applicable, dual-fuel engines							
3.12.1.	<i>Feed pump</i>				N/A			
3.12.1.1.	Pressure (kPa) or characteristic diagram:			X	N/A			
3.12.2.	<i>Injection system</i>				N/A			
3.12.2.1.	Pump				N/A			
3.12.2.1.0.	Make:			X	N/A			
3.12.2.1.1.	Type(s):			X	N/A			
3.12.2.1.2.	Rated pump speed (rpm):			X	N/A			
3.12.2.1.3.	mm ³ per stroke or cycle at full injection at rated pump speed:			X	N/A			
3.12.2.1.4.	Torque peak pump speed (rpm):			X	N/A			
3.12.2.1.5.	mm ³ per stroke or cycle at full injection at torque peak pump speed			X	N/A			
3.12.2.1.6.	Characteristic diagram:			X	N/A			
3.12.2.1.7.	Method used: on engine/on pump bench			X	N/A			
3.12.2.2.	Injection timing				N/A			
3.12.2.2.1.	Injection timing curve:			X	N/A			
3.12.2.2.2.	Static Timing:			X	N/A			
3.12.2.3.	Injection piping				N/A			
3.12.2.3.1.	Length(s) (mm):			X	N/A			
3.12.2.3.2.	Internal diameter (mm):			X	N/A			
3.12.2.4.	Common rail: Yes/No			X	No			

Item Number	Item Description	Test	Installation	Homologation	Parent engine/ engine type	Engine types within the engine family (if applicable)		
3.12.2.4.0.	Make:			X	N/A			
3.12.2.4.1.	Type:			X	N/A			
3.12.3.	<i>Injector(s)</i>				N/A			
3.12.2.0.	Make:			X	N/A			
3.12.3.1.	Type(s):			X	N/A			
3.12.3.2.	Opening pressure (kPa):			X	N/A			
3.12.4.	<i>Electronic control unit (ECU): Yes/No</i>			X	No			
3.12.4.0.	Make:			X	N/A			
3.12.4.1.	Type(s):			X	N/A			
3.12.4.2.	Software calibration number(s):			X	N/A			
3.12.4.3.	Communication standard(s) for access to data stream information: ISO 27145 with ISO 15765-4 (CAN-based)/ISO 27145 with ISO 13400 (TCP/IP-based)/SAE J1939-73	X		X	N/A			
3.12.5.	<i>Governor</i>				N/A			
3.12.5.0.	Make:			X	N/A			
3.12.5.1.	Type(s):			X	N/A			
3.12.5.2.	Speed at which cut-off starts under full load:			X	N/A			
3.12.5.3.	Maximum no-load speed:			X	N/A			
3.12.5.4.	Idle speed:			X	N/A			
3.12.6.	<i>Cold-start system: Yes/No</i>			X	No			
3.12.6.0.	Make:			X	N/A			
3.12.6.1.	Type(s):			X	N/A			

Item Number	Item Description	Test	Installation	Homologation	Parent engine/ engine type	Engine types within the engine family (if applicable)		
3.12.6.2.	Description:			X	N/A			
3.12.7.	<i>Fuel temperature at the inlet to the fuel injection pump</i>				N/A			
3.12.7.1.	Minimum (deg. C):	X			N/A			
3.12.7.2.	Maximum (deg. C):	X			N/A			
3.13.	Fuel feed for liquid fuel spark ignition engine							
3.13.1.	<i>Carburettor</i>				Refer to drawing No. ZMG1E36F- 04			
3.13.1.0.	Make:			X	ZOMAX WALBRO			
3.13.1.1.	Type(s):			X	PZ11JZ33T WYK484			
3.13.2.	<i>Port fuel injection:</i>				N/A			
3.13.2.1.	single-point / multi-point			X	N/A			
3.13.2.2.	Make:			X	N/A			
3.13.2.2.	Type(s):			X	N/A			
3.13.3.	<i>Direct injection:</i>				N/A			
3.13.3.0.	Make:			X	N/A			
3.13.3.1.	Type(s):			X	N/A			
3.13.4.	<i>Fuel temperature at location specified by manufacturer</i>				N/A			
3.13.4.1.	Location:	X			N/A			
3.13.4.2.	Minimum (deg. C)	X			N/A			

Item Number	Item Description	Test	Installation	Homologation	Parent engine/ engine type	Engine types within the engine family (if applicable)		
3.13.4.3.	Maximum (deg. C)	X			N/A			
3.14.	Fuel feed for gaseous fuel engines or where applicable, dual fuel engines (in the case of systems laid out in a different manner, supply equivalent information)							
3.14.1.	<i>Fuel: LPG /NG-H/NG-L /NG-HL/LNG/Fuel specific LNG</i>	X		X	N/A			
3.14.2.	<i>Pressure regulator(s) or vapouriser/pressure regulator(s)</i>				N/A			
3.14.2.0.	Make:			X	N/A			
3.14.2.1.	Type(s):			X	N/A			
3.14.2.2.	Number of pressure reduction stages			X	N/A			
3.14.2.3.	Pressure in final stage minimum and maximum. (kPa)			X	N/A			
3.14.2.4.	Number of main adjustment points:			X	N/A			
3.14.2.5.	Number of idle adjustment points:			X	N/A			
3.14.3.	<i>Fuelling system: mixing unit/gas injection/liquid injection/direct injection</i>			X	N/A			
3.14.3.1.	Mixture strength regulation				N/A			
3.14.3.1.1.	System description and/or diagram and drawings:			X	N/A			
3.14.4.	<i>Mixing unit</i>				N/A			
3.14.4.1.	Number:			X	N/A			
3.14.4.2'.	Make:			X	N/A			
3.14.4.2.	Type(s):			X	N/A			

Item Number	Item Description	Test	Installation	Homologation	Parent engine/ engine type	Engine types within the engine family (if applicable)		
3.14.4.3.	Location:			X	N/A			
3.14.4.4.	Adjustment possibilities:			X	N/A			
3.14.5.	<i>Inlet manifold injection</i>				N/A			
3.14.5.1.	Injection: single-point/multi-point			X	N/A			
3.14.5.2.	Injection: continuous/simultaneously timed/ sequentially timed			X	N/A			
3.14.5.3.	Injection equipment				N/A			
3.14.5.3.0.	Make:			X	N/A			
3.14.5.3.1.	Type(s):			X	N/A			
3.14.5.3.2.	Adjustment possibilities:			X	N/A			
3.14.5.4.	Supply pump				N/A			
3.14.5.4.0.	Make:			X	N/A			
3.14.5.4.1.	Type(s):			X	N/A			
3.14.5.5.	Injector(s)				N/A			
3.14.5.5.0.	Make:			X	N/A			
3.14.5.5.1.	Type(s):			X	N/A			
3.14.6.	<i>Direct injection</i>				N/A			
3.14.6.1.	Injection pump/pressure regulator			X	N/A			
3.14.6.1.0.	Make:			X	N/A			
3.14.6.1.1.	Type(s):			X	N/A			
3.14.6.1.2.	Injection timing (specify):			X	N/A			
3.14.6.2.	Injector(s)				N/A			
3.14.6.2.0.	Make:			X	N/A			

Item Number	Item Description	Test	Installation	Homologation	Parent engine/ engine type	Engine types within the engine family (if applicable)		
3.14.6.2.1.	Type(s):			X	N/A			
3.14.6.2.2.	Opening pressure or characteristic diagram :			X	N/A			
3.14.7.	<i>Electronic Control Unit (ECU)</i>				N/A			
3.14.7.0.	Make:			X	N/A			
3.14.7.1.	Type(s):			X	N/A			
3.14.7.2.	Adjustment possibilities:			X	N/A			
3.14.7.3.	Software calibration number(s):			X	N/A			
3.14.8.	<i>Approvals of engines for several fuel compositions</i>				N/A			
3.14.8.1.	Self-adaptive feature: Yes/No	X	X	X	No			
3.14.8.2.	Calibration for a specific gas composition: NG-H/NG-L/NG-HL/ LNG/Fuel specific LNG	X	X	X	N/A			
3.14.8.3.	Transformation for a specific gas composition: NG-HT/NG-LT/NG-HLT	X	X	X	N/A			
3.14.9.	<i>Fuel temperature pressure regulator final stage</i>				N/A			
3.14.9.1.	Minimum (deg. C):	X			N/A			
3.14.9.2.	Maximum (deg. C):	X			N/A			
3.15.	Ignition system							
3.15.1.	<i>Ignition coil(s)</i>							
3.15.1.0.	Make:			X	ZOMAX			
3.15.1.1.	Type(s):			X	4.009.0023.13			
3.15.1.2.	Number:			X	1			
3.15.2.	<i>Spark plug(s)</i>							

Item Number	Item Description	Test	Installation	Homologation	Parent engine/ engine type	Engine types within the engine family (if applicable)		
3.15.2.0.	Make:			X	Champion TORCH			
3.15.2.1.	Type(s):			X	RCJ6Y L8RTF			
3.15.2.2.	Gap setting:			X	N/A			
3.15.3.	<i>Magneto</i>							
3.15.3.0	Make(s):			X	N/A			
3.15.3.1.	Type(s):			X	N/A			
3.15.4.	<i>Ignition timing control: Yes/No</i>			X	Yes			
3.15.4.1.	Static advance with respect to top dead centre (crank angle degrees):			X	N/A			
3.15.4.2.	Advance curve or map:			X	Refer to drawing No. ZMG1E36F- 06			
3.15.4.3.	Electronic control: Yes/No			X	No			

Attachment 1 Photographs of the engines



Attachment 2 Drawings of the engines

Location of Engine No (Paste)

Engine Type
 Type+ YY/MM+ Serial No.



Engine Identification number



Location of EC Approval No. (Paste)

e24*2016/1628*2016/1628????*????*00

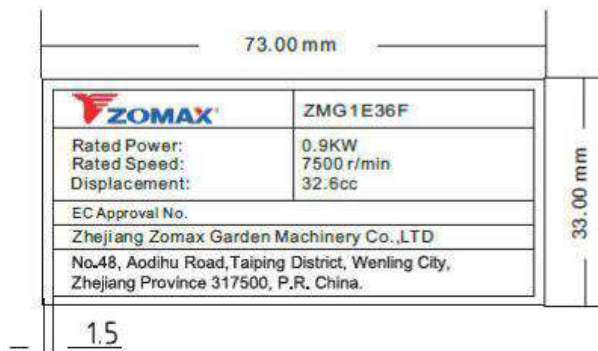

Note:

The Font and number height are 1.8mm.

Engine type	ZMG1E36F
Position of engine No. and EC approval No.	
Drawing No.	ZMG1E36F-01

Part No: 4.002.0011.17

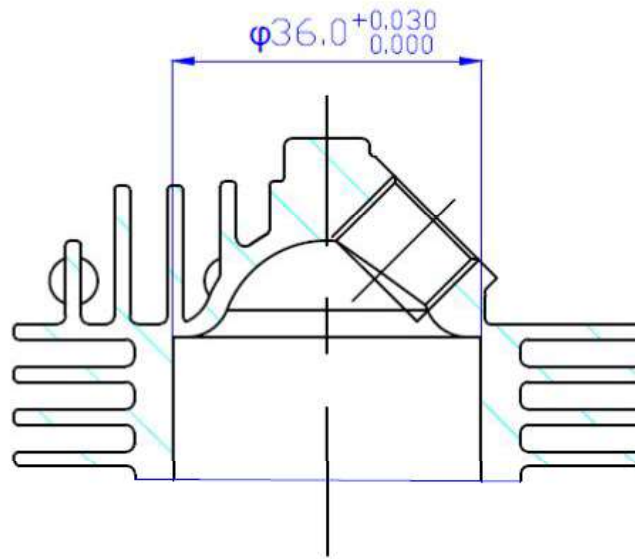

Engine type	ZMG1E36F
Header	
Drawing No.	ZMG1E36F-02

Part No: 4.004.0013.14

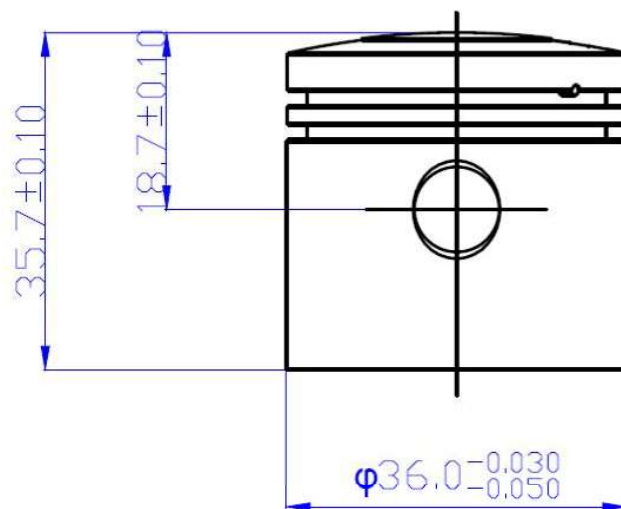

Engine type	ZMG1E36F
Piston	
Drawing No.	ZMG1E36F-03

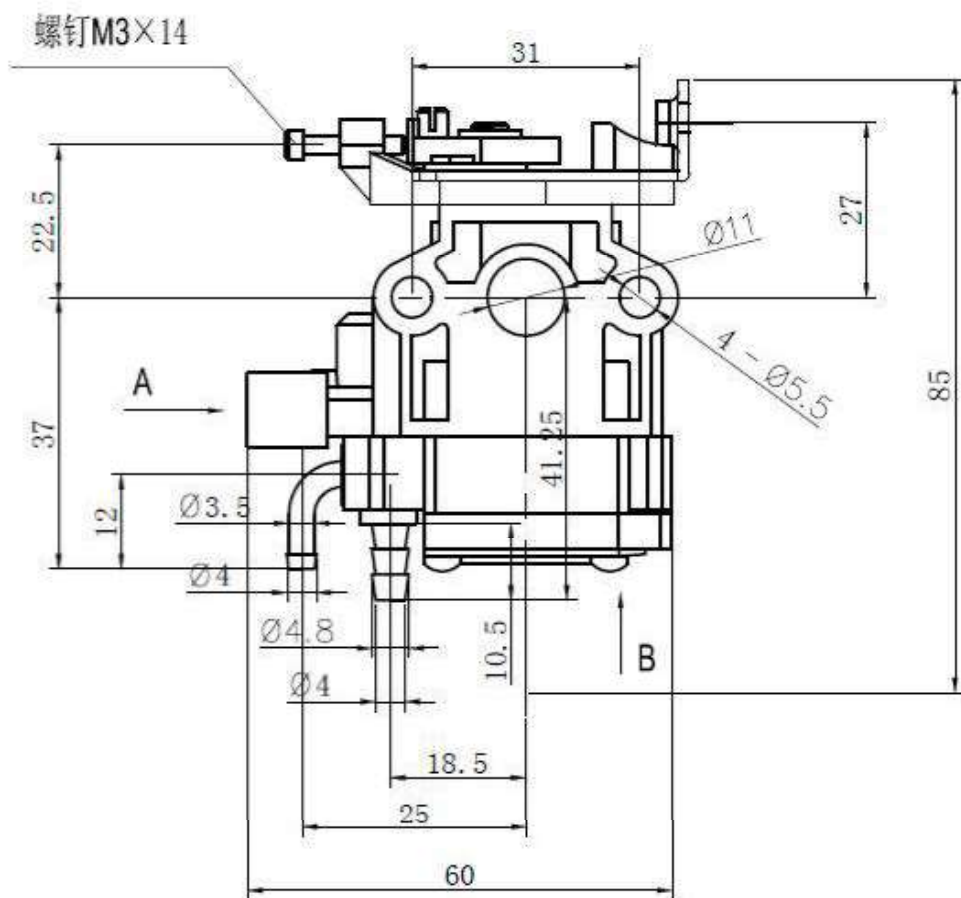

Engine type	ZMG1E36F
Carburetor	
Drawing No.	ZMG1E36F-04

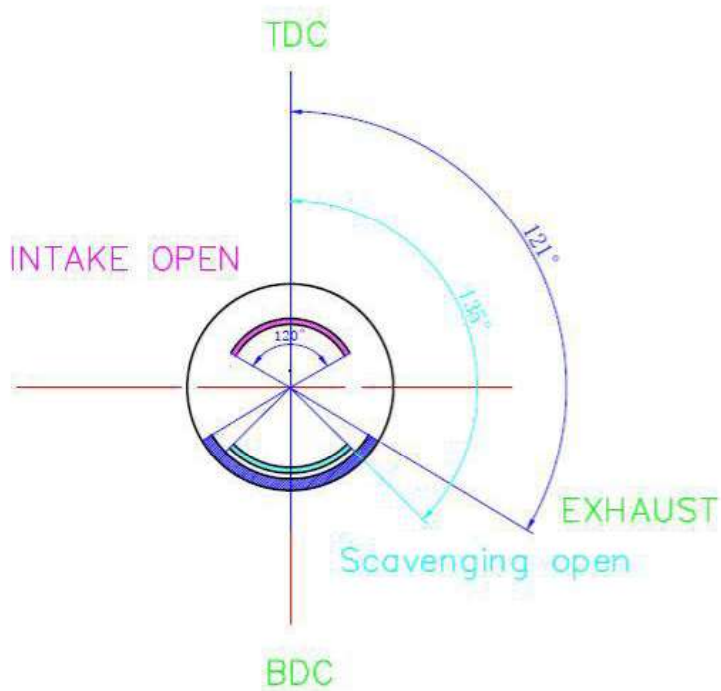

Engine type	ZMG1E36F
Valve timing	
Drawing No.	ZMG1E36F-05

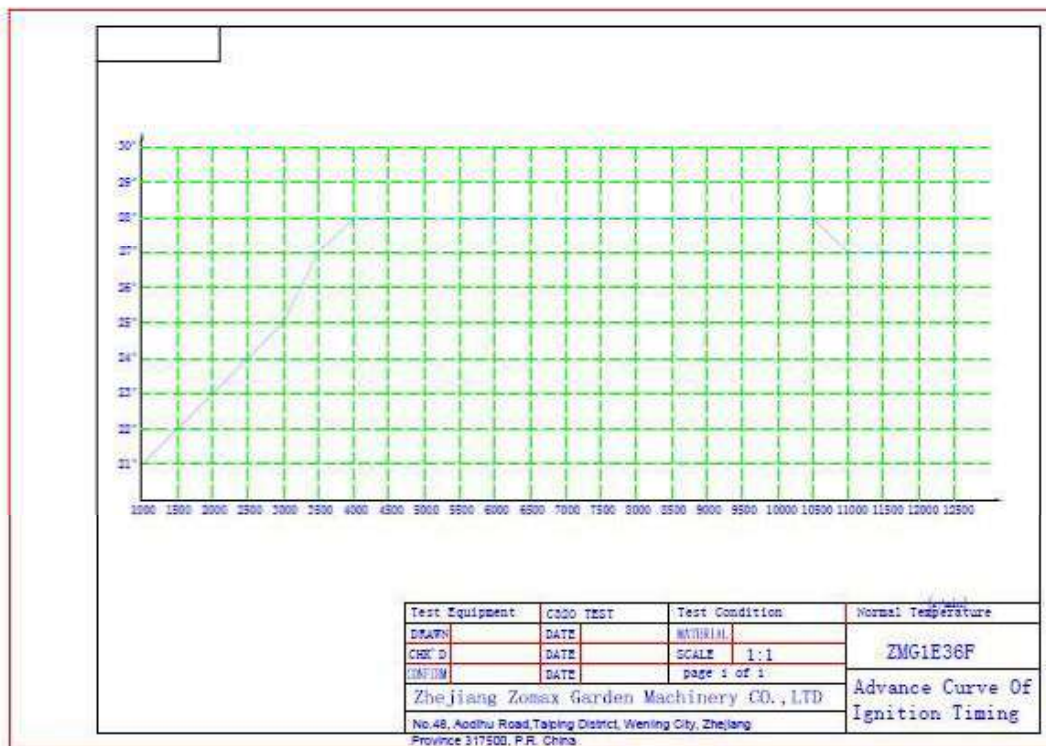

Engine type	ZMG1E36F
Ignition advance curve	
Drawing No.	ZMG1E36F-06

Part No: 4.006.0012.14

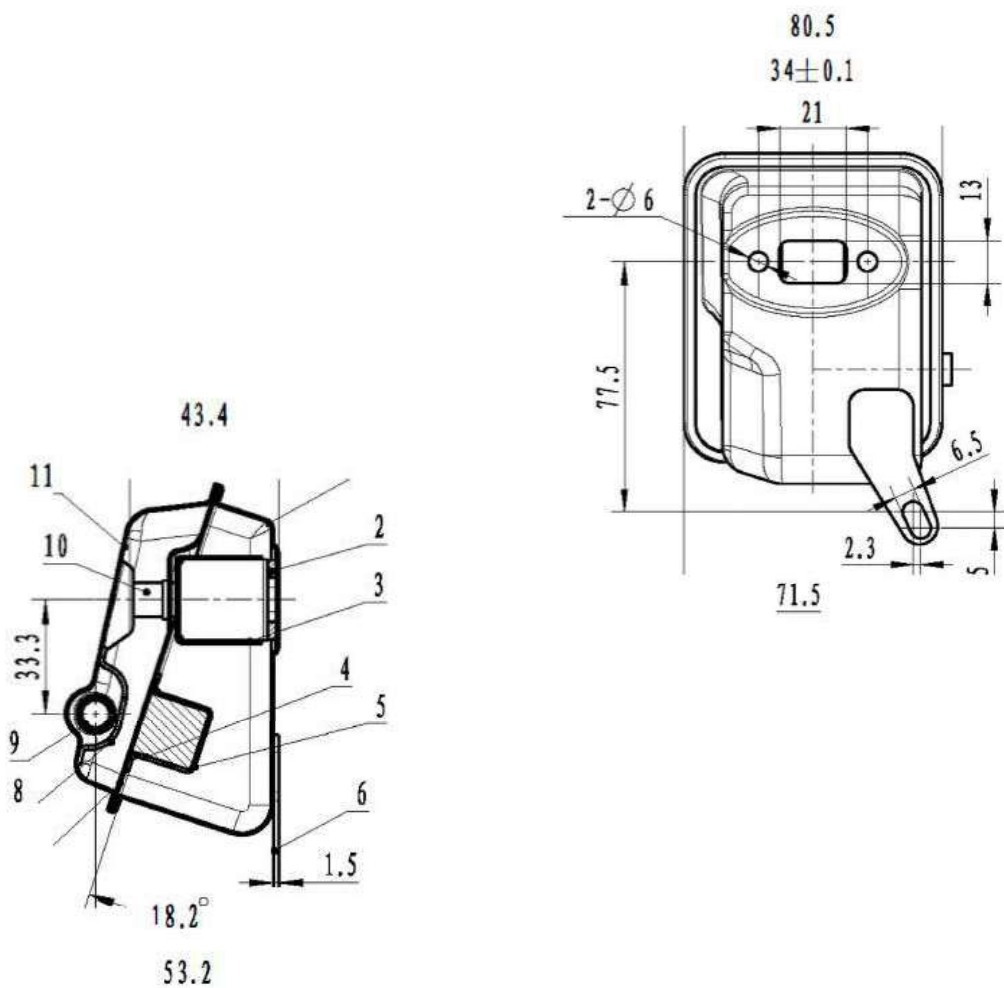

Engine type	ZMG1E36F
Muffler	
Drawing No.	ZMG1E36F-07

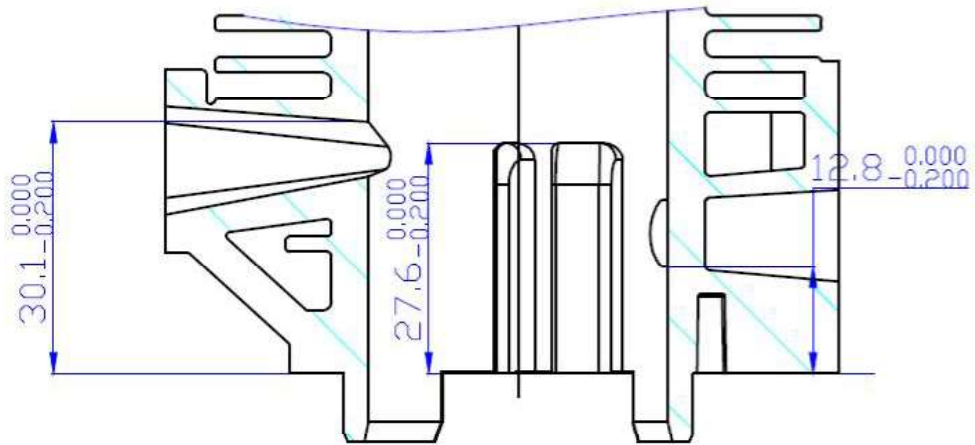

Engine type	ZMG1E36F
Inlet path	
Drawing No.	ZMG1E36F-08

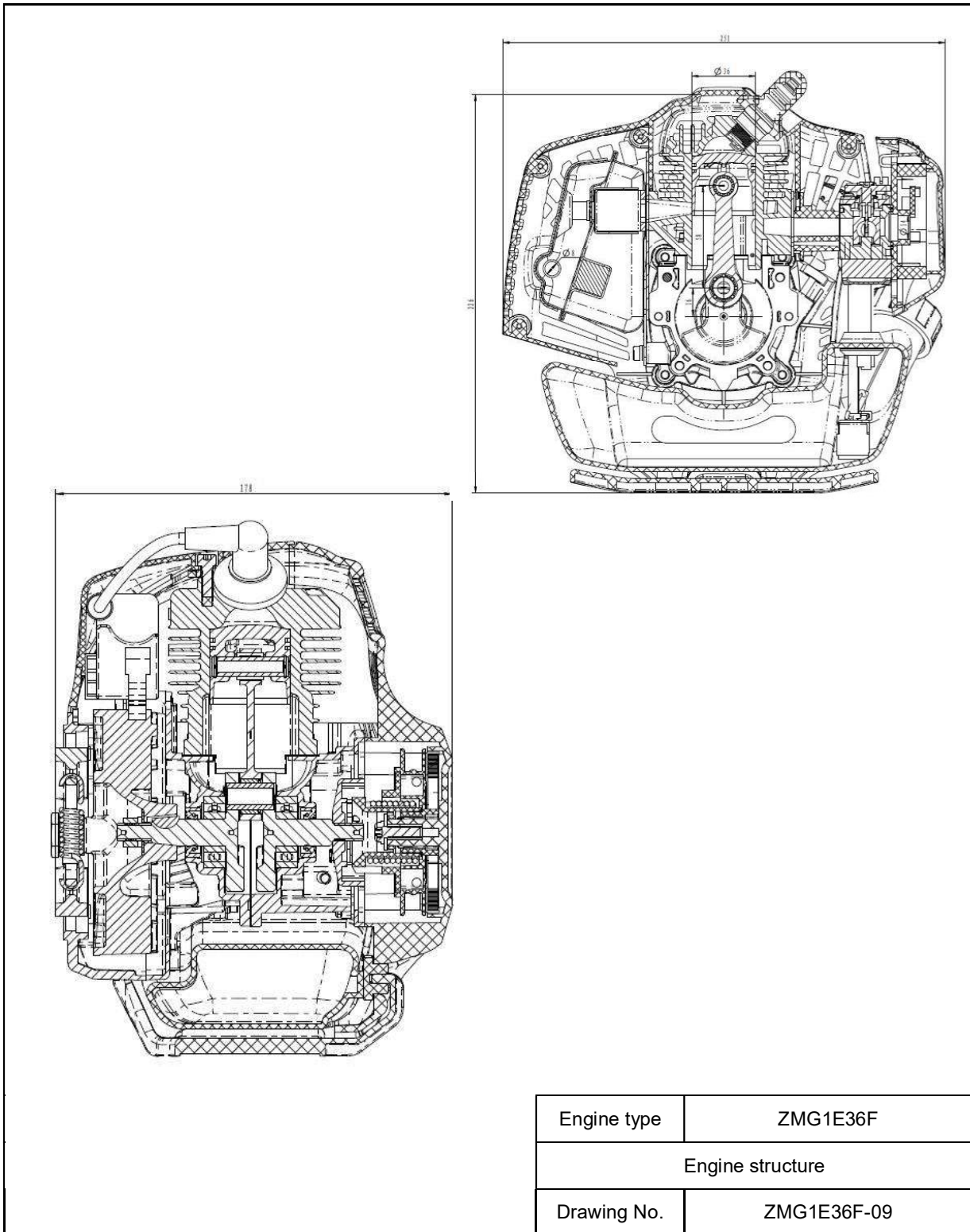

Attachment 4 **Manufacturer’s statement on compliance with the exhaust emission limits when use fuels other than the reference fuels**

N/A

Attachment 5 **Overview of the emission control strategy for electronically controlled engines**

N/A

Attachment 6 **The functional operational characteristics of the NOx control measures and inducement system**

N/A

Attachment 7 **The functional operational characteristics of the particulate control measures**

N/A

Attachment 9 Manufacturer's declaration, and supporting test reports or data, of the infrequent regeneration adjustment factors

N/A

Attachment 10 The physical connector required to receive the torque signal from the engine Electronic control Unit (ECU) during the in-service monitoring test

N/A

Attachment 11 Manufacturer’s declaration and supporting data on tampering prevention for emission control systems

We, ZHEJIANG ZOMAX GARDEN MACHINERY CO., LTD., Hereby declares that the emission control strategies of the following engine type/engine family fitted are designed in such a way as to prevent tampering to the extent possible, as referred to in Article 18(4) of Regulation (EU) 2016/1628 of the European Parliament and of the Council and Annex X of Commission Implementing Regulation (EU) 2017/656.

- 1.1. Make (trade name(s) of manufacturer) : ZOMAX
- 1.2. Commercial name(s) (if applicable) : N/A
- 1.3. Company name and address of manufacturer : ZHEJIANG ZOMAX GARDEN MACHINERY CO., LTD.
 No.48 Aodihu Road, Taiping District, Wenling City, Zhejiang Province, China
- 1.4. Name and address of manufacturer’s authorised representative (if any) : Brumar Garden Product S.r.l
 Loc. Valgera 110/B-14100 ASTI (AT)-ITALY
- 1.6. Engine type designation/engine family designation/FT : Parent engine: ZMG1E36F
 Commercial names: N/A
 Engine within family: N/A
 Commercial names: N/A

Technical details:

	Photograph	Description
1		<p>The adjusting screw is flower-shaped, only possible to be adjusted by manufacture by using the special screwdriver, and the screwdriver will not available on the market. If the user want to use other device to adjust it, the screw head will be destroyed.</p>

Attachment 12 List of scheduled for emission-related maintenance requirements

Proper maintenance is essential for safe, economical and trouble-free operation. It also helps reduce air pollution. In order to keep your gasoline engine in good working condition, it must be periodically serviced. The following maintenance schedule and routine inspection procedures must be carefully followed.

Frequency		Every time	First month or 10 hrs of operation	Thereafter, every 3 months or 30hrs of operation	Every 6 months or 50 hrs of operation	Every year or 100 hrs of operation
Engine oil	Check-Refill	√				
	Change		√	√		
Air filter element	Check	√				
	Clean			√		
	Change				√	
Spark plug	Clean-adjust				√*	
Spark arrester	Clean				√	
Valve clearance**	Check-adjust					√
Fuel hose	Check	Every 2 years (change if necessary)				
Cylinder head, Piston**	Remove carbon deposits	Every 50 hours				
* These items should be replaced by new ones if necessary. ** These items should be serviced by a mechanically proficient person or by our authorized servicing dealer.						